

PLAN

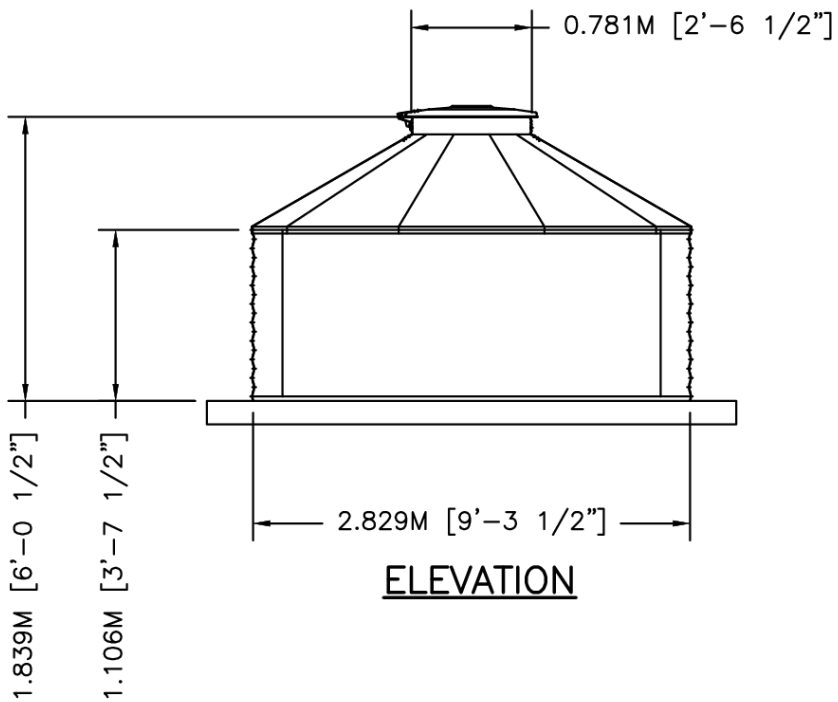

ELEVATION



	BY	DATE	TITLE	
DWN	XXX	XX/XX/XX	WTU03-01 30"PR 30DEG FLAT PANEL NOMINAL CAPACITY - 6.148 M3 [1,624 GAL]	
CKD			DWG. NO.	REV. NO.
ENG			SCT901-FP WTU03-01	
SIZE:		SCALE:	SHEET	OF
A		1/4"=1'-0"	1	1